

# SpectrALL Spectra-RGB Precision RGB Reference Sources



info@amstechnologies.com  
www.amstechnologies.com  
shop.amstechnologies.com

**Get expert guidance now!** 

**High brightness RGB uniform source. Stable and repeatable references with peak wavelength and system configurations available to match testing needs – from the benchtop to production!**

#### Trusted test data

Labsphere is a recognized leader in traceable reference sources. Our precision RGB reference sources are engineered for the high-performance requirements in image sensor research, waveguide characterization, and imaging colorimeter calibration for development, production testing, and calibration programs.

#### Repeatable, reproducible results – Every Time!

With Labsphere’s proprietary diffuse reflectance material, Spectralon®, screened and binned LED sources, and thermally controlled source modules, long term repeatability and reproducibility are ensured.

#### Self-contained, simple and reliable

Labsphere’s platform is engineered to operate seamlessly in the lab as well as automated test platforms. Commissioning software provides intuitive setup while a universal command interface ensures easy integration into test equipment and sequences. Internal monitoring provides system performance and health feedback in real time. The software allows scripting of specific set points for testing sequences that can be programmed for your unique applications and testing requirements.



#### Wavelength precision

Our precision RGB reference sources are thermally controlled with mechanical attenuators that enable repeatable peak wavelength stability. The temperature control and mechanical attenuators enable more repeatable and wavelength- stable performance. These systems will stay within the 10 nm wavelength range.

#### Key Performance

- Fast rise and settling times between RGB test conditions
- High luminance level and uniformity
- Form factor for production tester integration
- Peak wavelength stability

#### Features

- High speed attenuators for fast spectral transitioning
- Spectral radiance monitoring for confidence in color and peak wavelength stability
- Ability for user calibration and characterization optimization over the life of the product

# Specifications

## Key Parameters

---

Luminance Range:	50 - 2,000,000 nits at 6500K CCT
Wavelength Shift:	± 5 nm (over Luminance Range from 10% to 90% available output)
Clear Field of View (FoV) at Port:	45 mm x 65 mm x 75° full angle (H x W x Diagonal)
Spatial Luminance Uniformity:	Greater than 97% uniformity (evaluated over 90% clear aperture)
Angular Luminance Uniformity:	96% (over ± 30°, evaluated at center)
Luminance Stability - Short Term:	± 1.0% P-P, 1 min.
Luminance Stability - Long Term:	± 2.0% P-P, 1 hr.

## Spectral Performance

---

Wavelength Repeatability:	± 2 nm (same system, day to day)
Peak Wavelength Stability:	< 1 nm over 1 hour at steady state, ± 5 nm from 10% to 90% output

## Spectral Output

### Nominal (Initial Tolerance Range)

---

Red Peak Wavelength:	624 nm (619 - 629 nm)
Green Peak Wavelength:	519 nm (514 - 524 nm)
Blue Peak Wavelength:	447 nm (442 - 452 nm), 470 nm (465 - 475 nm)

## Control and Calibration

---

Luminance Adjustability:	LED Current Control 16 bit and Variable Attenuator Control ~14 bit
Variable Attenuator Speed:	< 1 sec (open to closed)
Thermal Control:	TEC and Liquid Cooling
Spectral Monitor:	Multispectral Detector
Internal Calibration Source:	Spectral Radiance Transfer Source

## Mechanical

---

Luminance Port Diameter Options:	16 mm, 20 mm, and 25.4 mm
Luminance Port Orientation:	Up, Down, and Side (feet and mounting interfaces provided)
RGB Source Dimensions:	27.6 x 27.6 x 26.4 cm (10.88 x 10.88 x 10.38 in.) (H x W x D)
RGB Source Weight:	13 kg (28.7 lbs.)
Heat Exchanger Dimensions:	17.1 x 30.5 x 8.3 cm (6.75 x 12.00 x 3.25 in.) (H x W x D)
Heat Exchanger Weight:	5.7 kg (12.5 lbs.)
Heat Exchanger Positioning Options:	Flexible (1, 2, 3, and 6 m tubing lengths available)

## Electrical and Control

---

Power Input:	100 - 240 VAC, 50/60 Hz, <12 A
Command Control Interface:	RS-232 (over USB)

## Safety and Environmental

---

Certification:	CE Certified
Operating Temperature:	15 - 35°C

# Spectra-RGB Precision Source (Silver) Ordering Information:

Choose one from each column

Family	Level	Sphere Diameter	Exit Port Size	Cooling and Line Length	Red Peak Wavelength $\lambda_p$ (initial tolerance +/- 5 nm)	Green Peak Wavelength $\lambda_p$ (initial tolerance +/- 5 nm)	Blue Peak Wavelength $\lambda_p$ (initial tolerance +/- 5 nm)	Attenuator	Monitor
Spectra-RGB	S   Silver	SD10   10 cm	EP16   16 mm	CL1   1 m	R624T05   624 nm (619 - 629 nm)	G519T05   519 nm (514 - 524 nm)	B447T05   447 nm (442 - 452 nm)	VA - Variable Attenuator	DETFB - Via Detector
			EP20   20 mm	CL2   2 m			B470T05   470 nm (465 - 475 nm)		
			EP25   25 mm	CL3   3 m					
				CL6   6 m					

Ordering Example: Spectra-RGB-S-SD10-EP20-CL2-R624T05-G519T05-B447T05-VA-DETFB

Standard Features: Variable Light Attenuator, Detector Monitor

## Product Dimensions

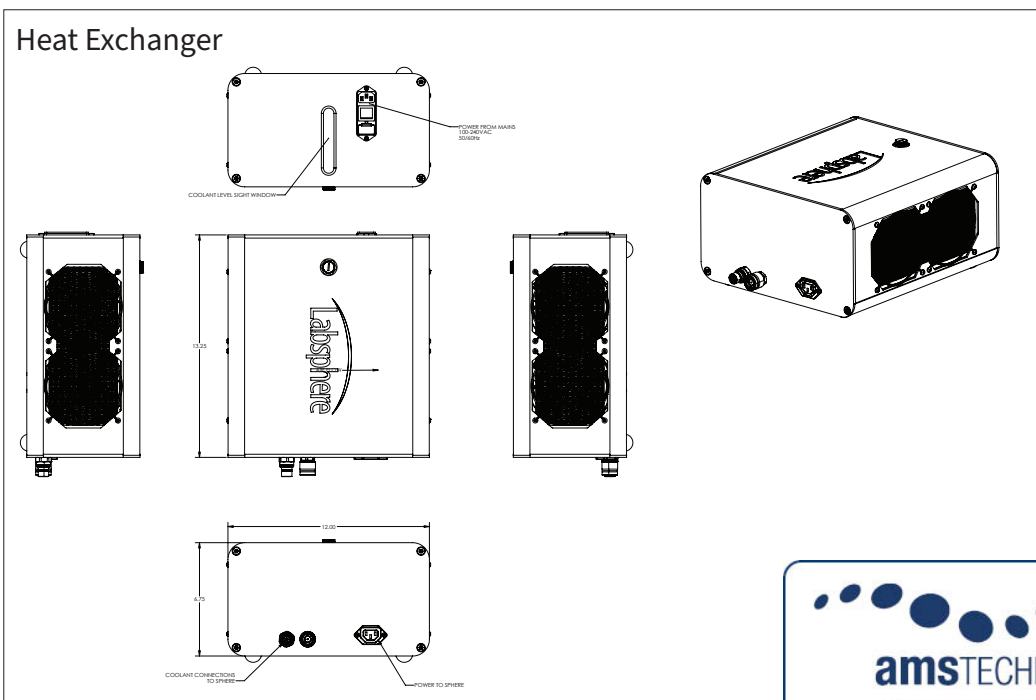
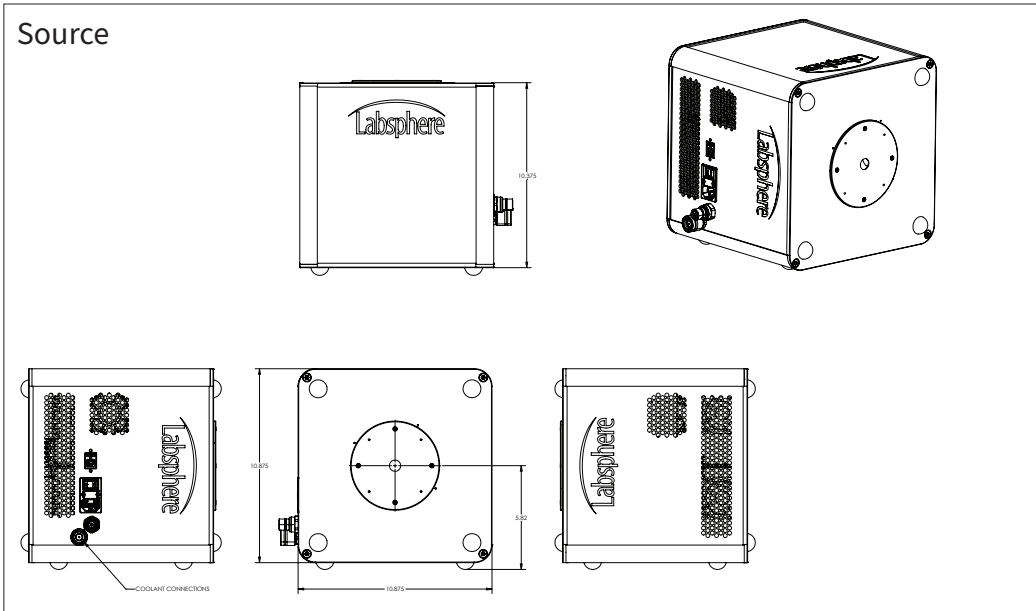

[info@amstechnologies.com](mailto:info@amstechnologies.com)  
[www.amstechnologies.com](http://www.amstechnologies.com)  
**amSTECHNOLOGIES** [shop.amstechnologies.com](http://shop.amstechnologies.com)  
**Get expert guidance now!**

